

ECO-COMBI 3

MULTI-HEAT ENERGY BUFFER WITH STAINLESS STEEL 316L D.H.W. CORRUGATED COIL AND 2 FIXED HEAT EXCHANGERS



APPLICATION

Heating hot water storage and rapid D.H.W. production.

MATERIAL

- BUFFER TANK: Mild steel construction with exterior paint. No anti-corrosion treatment required due to the buffer's closed circuit system.
- D.H.W. STORAGE : Stainless steel 316L corrugated coil, suitable for D.H.W. according to D. M. n. 174 dated 06.04.04

HEAT EXCHANGER

N° 2 fixed heat exchangers.

TECHNICAL DESCRIPTION

Multi-Heat Energy tanks EcoCombi 3 are used in units with a typically discontinuous energy source for double use: heating system and sanitary hot water system .

- Heating system with a biomass generator as energy source, combining the possibility to produce hot water for sanitary use. In such case , storage heating volume allows the generator to regularly work , limiting number of stops due to the inadequate energy request of the heating system. Moreover, it limits the emission of smoke and the creation of corrosive condensate (smoke side).
- Domestic hot water production system for domestic and sanitary use where heating water is stored. In this system , the high potentiality

of the Eco Combi allows to obtain a good production of hot sanitary water even if temperatures of the primary system are not so high (i.e using heat pumps as primary source and solar source as support)

The particular shape of the corrugated coil is avoiding any problem relating to the storage of sanitary hot water and ensure high heat exchange performances.

INSULATION

- HARD: High thermal insulation with ecological polyurethane hard foam.

- SOFT: NOFIRE® polyester fleece 100% made of recyclable material, with high thermal insulation. Fire resistance class B-s2d0 according to EN 13501. Grey PVC external lining.

WARRANTY

5 years - See general sales conditions and warranty

ACCESSORIES AND SPARE PARTS

See Accessories section for the entire list.



316L STAINLESS STEEL D.H.W. CORRUGATED COIL



STOCK AVAILABILITY



cordivari.com/erp

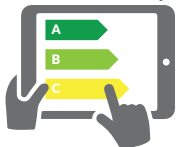

On line ErP label tool



ECO-COMBI 3 VB

Model	HARD FOAM insulation Art. Nr.	316L STAINLESS STEEL CORRUGATED COIL FOR D.H.W. PRODUCTION		UPPER HEAT EXCHANGER		LOWER HEAT EXCHANGER		ENERGY EFFICIENCY CLASS
		Volume [lt]	Surface [m ²]	Volume [lt]	Surface [m ²]	Volume [lt]	Surface [m ²]	
500	3270162316201	26,6	4,5	8	1,3	11,5	1,9	C
600	3270162316202	31,0	5,3	8	1,3	13	2,1	C
800	3270162316203	33,4	5,8	11,8	1,8	16,3	2,5	B
1000	3270162316204	45,5	7,8	16,3	2,5	20,7	3,1	C
1250	3270162316205	45,5	7,8	16,3	2,5	22,3	3,4	B
1500	3270162316206	55,3	9,5	16,8	2,8	25,3	3,8	C
2000	3270162316207	72,2	12,3	19,1	2,8	29,6	4,6	B



ECO-COMBI 3 VC

Model	DISMOUNTABLE SOFT FLEECE insulation Art. Nr.	316L STAINLESS STEEL CORRUGATED COIL FOR D.H.W. PRODUCTION		UPPER HEAT EXCHANGER		LOWER HEAT EXCHANGER		ENERGY EFFICIENCY CLASS
		Volume [lt]	Surface [m ²]	Volume [lt]	Surface [m ²]	Volume [lt]	Surface [m ²]	
800	3270162282282	33,4	5,8	11,8	1,8	16,3	2,5	C
1000	3270162282283	45,5	7,8	16,3	2,5	20,7	3,1	C
1250	3270162282284	45,5	7,8	16,3	2,5	22,3	3,4	C
1500	3270162282285	55,3	9,5	16,8	2,8	25,3	3,8	C
2000	3270162282286	72,2	12,3	19,1	2,8	29,6	4,6	C

ACCESSORIES

THREEPHASE and MONOPHASE Electric immersion heaters

Available kit:	
[Kw]	Tension [V]
da 1,5 a 3	220 - MONOPHASE
da 4 a 9	400 - THREEPHASE
See accessories	

Thermometer

Art. Nr.	
5032240000107	
5 units box	

Buffer tanks connecting kit

Art. Nr.	Connection	
5006170001001	1" 1/2	
Stainless steel extensible connecting kit - (200 ÷ 400 mm)		



ECO-COMBI 3

MULTI-HEAT ENERGY BUFFER WITH STAINLESS STEEL 316L D.H.W. CORRUGATED COIL AND 2 FIXED HEAT EXCHANGERS

STORAGE	CORRUGATED DHW STAINLESS STEEL COIL	FIXED HEAT EXCHANGER
Pmax Tmax 3 bar 99 °C	Pmax 6 bar	Pmax Tmax 12 bar 110 °C



CORDIVARI Lab

TÜV Rheinland Energie und Umwelt GmbH states that test procedures and Cordivari LAB are certified conforming to European standard EN 15332, as indicated by Ecodesign ErP Directive.

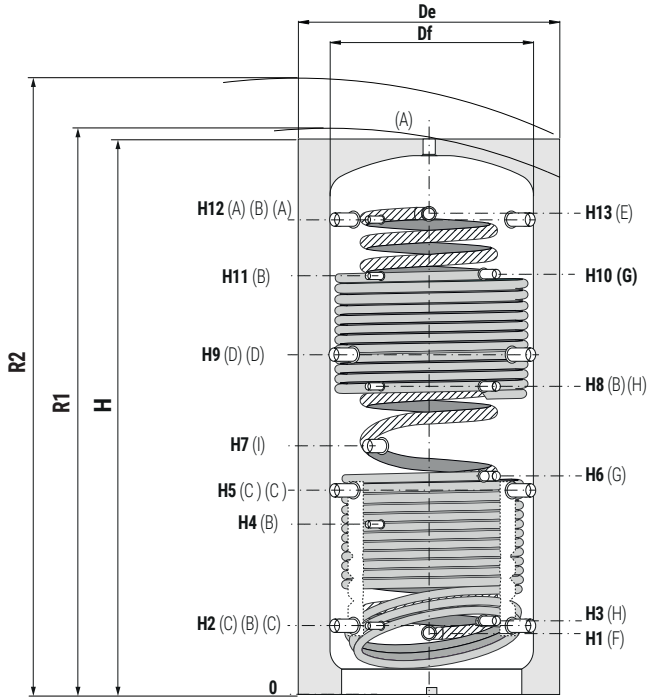
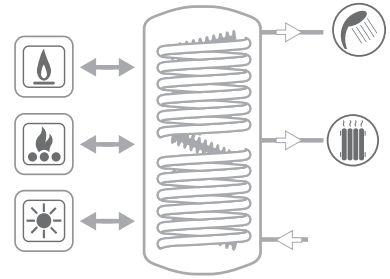

A	Heating delivery/From generator/air purge 1"1/2 F
B	Probe 1/2" F
C	Heating return/to generator
D	Heating delivery/From generator 1"1/2 F
E	Domestic hot water circuit outlet 1".
F	Domestic cold water circuit inlet 1" M.
G	Heat exchanger inlet 1" F
H	Heat exchanger outlet 1" F
I	Connection for electric immersion heater 1"1/2 F

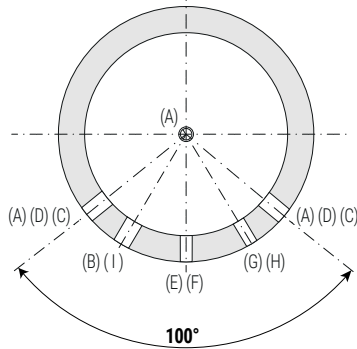

ECO-COMBI 3 VB - HARD FOAM INSULATION

Model	Volume [lt]	Dimensions [mm]																	
		Df	De	H	R1	R2	H1	H2	H3	H4	H5	H6	H7	H8	H9	H10	H11	H12	H13
500	478	//	750	1620	//	1800	230	247	260	533	629	744	841	930	1011	1231	1231	1343	1360
600	560	//	750	1870	//	2025	230	247	260	582	695	855	915	1060	1144	1361	1382	1593	1610
800	803	790	940	1840	1895	2070	248	265	278	584	690	762	823	988	1115	1332	1332	1541	1558
1000	944	790	940	2130	2180	2340	248	265	284	656	787	953	998	1188	1309	1661	1588	1831	1843
1250	1248	//	1100	2202	//	2475	296	313	326	705	835	884	986	1068	1357	1641	1586	1879	1896
1500	1432	//	1100	2250	//	2505	296	313	336	736	845	1006	1061	1286	1377	1673	1653	1909	1921
2000	1970	//	1300	2320	//	2670	330	347	370	770	879	1001	1060	1300	1411	1687	1687	1943	1955

ECO-COMBI 3 VC - DISMOUNTABLE SOFT FLEECE INSULATION

Model	Volume [lt]	Dimensions [mm]																	
		Df	De	H	R1	R2	H1	H2	H3	H4	H5	H6	H7	H8	H9	H10	H11	H12	H13
800	803	790	1010	1840	1895	2100	248	265	278	584	690	762	823	988	1115	1332	1332	1541	1558
1000	944	790	1010	2130	2180	2370	248	265	284	656	787	953	998	1188	1309	1661	1588	1831	1843
1250	1248	900	1120	2202	2262	2475	296	313	326	705	835	884	986	1068	1357	1641	1586	1879	1896
1500	1432	950	1210	2250	2315	2565	296	313	336	736	845	1006	1061	1286	1377	1673	1653	1909	1921
2000	1970	1100	1360	2320	2400	2700	330	347	370	770	879	1001	1060	1300	1411	1687	1687	1943	1955

ECO-COMBI

CORRUGATED COIL - PERFORMANCES DURING DHW PRODUCTION PHASE



COMPLETE HEATED STORAGE VOLUME

UPPER PART HEATED STORAGE VOLUME

Model	DHW Volume [lt]	DHW exchanger surface [m ²]	COMPLETE HEATED STORAGE VOLUME		UPPER PART HEATED STORAGE VOLUME	
			Max sanitary water produced from 10°C to 45°C with storage at 65°C and boiler on [lt/min]	Max sanitary water produced from 10°C to 45°C with storage at 65°C and boiler off [lt]	Max sanitary water produced from 10°C to 45°C with storage at 65°C and boiler on [lt/min]	Max sanitary water produced from 10°C to 45°C with storage at 65°C and boiler off [lt]
500	26,6	4,5	29	10 lt/min: 354 lt	15	10 lt/min: 102 lt
				25 lt/min: 227 lt		25 lt/min: 75 lt
600	31	5,3	34	10 lt/min: 400 lt	18	10 lt/min: 115 lt
				25 lt/min: 257 lt		25 lt/min: 85 lt
800	33,4	5,8	37	10 lt/min: 587 lt	23	10 lt/min: 218 lt
				25 lt/min: 377 lt		25 lt/min: 160 lt

LOWER HEAT EXCHANGER POWER - ECO COMBI 2 - ECO COMBI 3

Output of the EcoCombi 2 - EcoCombi 3 lower heat exchangers depending on the average DeltaT between primary and accumulation considering flow rate 3 m³/h.

Thermal output is given in both kW or kcal/h in terms of average temperature difference between primary and secondary circuit, all for a range of primary 3 m³/h.

For example, a 1000 liters ECOCOMBI 2 with a water flow of 3 m³/h at 80 °C inlet and outlet at 70 °C, has on the storage of water an average temperature of 60 °C, the main difference of temperature will be:
 $(80 + 70) / 20 - 60 = 15$ °C and therefore you can exchange up to approximately 32 kW.

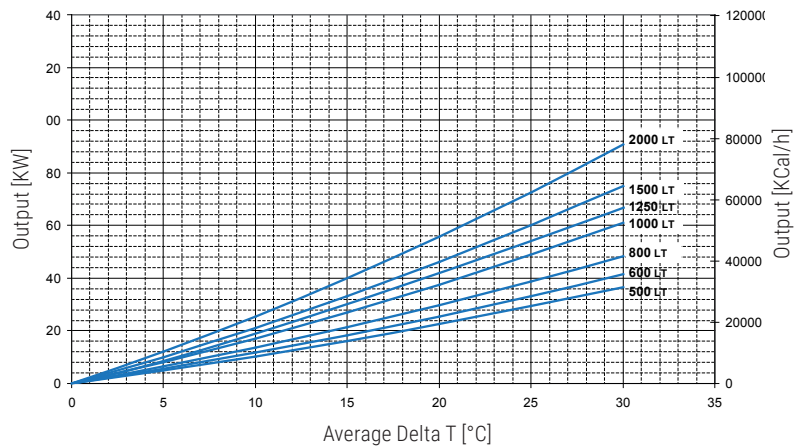

UPPER HEAT EXCHANGER POWER - ECO COMBI 3

Output of the EcoCombi 3 upper heat exchangers depending on the average DeltaT between primary and accumulation considering flow rate 3 m³/h.

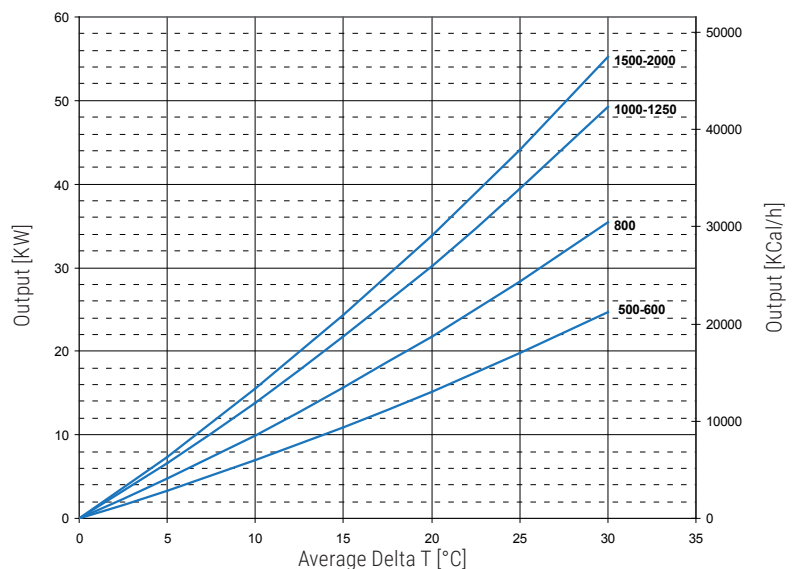

ECO-COMBI

CORRUGATED COIL - PERFORMANCES DURING DHW PRODUCTION PHASE



COMPLETE HEATED STORAGE VOLUME

UPPER PART HEATED STORAGE VOLUME

Model	DHW Volume	DHW exchanger surface	Max sanitary water produced from 10°C to 45°C with storage at 65°C and boiler on	Max sanitary water produced from 10°C to 45°C with storage at 65°C and boiler off	Max sanitary water produced from 10°C to 45°C with storage at 65°C and boiler on	Max sanitary water produced from 10°C to 45°C with storage at 65°C and boiler off
	[lt]	[m ²]	[lt/min]	[lt]	[lt/min]	[lt]
1000	45,5	7,8	50	10 lt/min: 800 lt	27	10 lt/min: 294 lt
				25 lt/min: 541 lt		25 lt/min: 216 lt
1250	45,5	7,8	50	10 lt/min: 922 lt	27	10 lt/min: 310 lt
				25 lt/min: 592 lt		25 lt/min: 230 lt
1500	55,3	9,5	57	10 lt/min: 1144 lt	34	10 lt/min: 345 lt
				25 lt/min: 735 lt		25 lt/min: 258 lt
2000	72,2	12,3	74	10 lt/min: 1657 lt	44	10 lt/min: 463 lt
				25 lt/min: 1142 lt		25 lt/min: 340 lt

LOWER HEAT EXCHANGER PRESSURE LOSS - ECO COMBI 2 - ECO COMBI 3

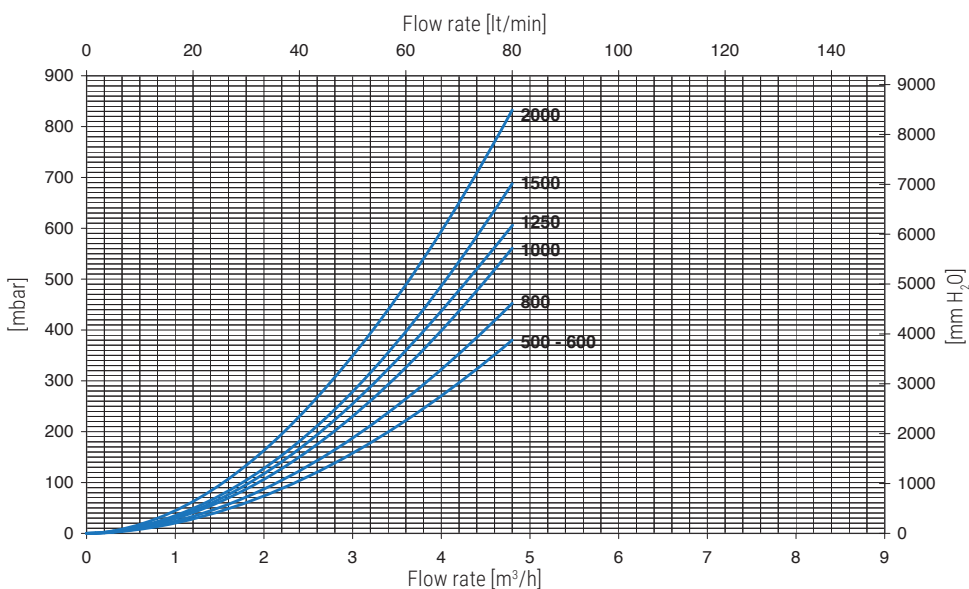

UPPER HEAT EXCHANGER PRESSURE LOSS - ECO COMBI 3

